

FLEXTEC[®] 500X

SIMPLE. RELIABLE. FLEXIBLE.



Powerful Performance From the Ground Up

Out in the shipyards, construction sites and fabrication shops, it pays to keep it simple. The Flextec 500X multi-process welder is easy to set up and operate, yet rugged enough to stand up to heavy-duty indoor and outdoor applications.

Basic pulse MIG capability is standard on the Flextec 500X, including weld modes for carbon steel, stainless steel, aluminum and metalcore electrodes.

The Flextec 500X welder is also equipped with CrossLinc[®] technology giving you the flexibility to control the machine from hundreds of feet away without a control cable.

Processes »

SMAW, GTAW, GMAW, GMAW-P, FCAW, Arc Gouging

Applications »

Fabrication, Shipbuilding, Construction

Output »



Input »



Product Number »

K3607-1 Flextec 500X
K3607-2 Flextec 500X CE

FEATURES

SIMPLE

- Simple interface for ease of use.
- CrossLinc technology eliminates extra cables for simple system setup.¹

RELIABLE

- IP 23 rating means the Flextec 500X welder will excel in outdoor environments, such as construction sites and shipyards.
- Flextec 500X welder is Desert Duty[®] rated for operation in the harshest environments (up to 55C).
- Durable trayed and potted PC boards for electronics environmental protection

FLEXIBLE

- Multi-process power source for all your welding needs.
- Compatible with all 42VAC wire feeders for MIG and Flux-Cored welding
- Arclink[®] enabled power source provides synergic pulse modes.²
- CrossLinc allows for remote control of CV and CC processes without extra cables.³
- Optimized stick welding for both cellulosic and low hydrogen electrodes.
- Touch-start Tig for easy, contamination free starts without high frequency.

CROSSLINC TECHNOLOGY COMPATIBILITY

- Full functionality without control cables
- Enables remote procedure setting at the feeder to improve weld quality
- Increases arc time with fewer trips to the power source to adjust settings
- Improves safety by reducing jobsite clutter

⁽¹⁾ Only with CrossLinc enabled

⁽²⁾ Requires Power Feed[®] wire feeder.

⁽³⁾ Requires CrossLinc technology enabled wire feeder, or CrossLinc remote.

FLEXIBILITY

Flextec power sources support multiple weld processes: MIG, TIG, Stick, Gouging and FCAW. Flextec welders can be used with nearly all Lincoln Electric wire feeders due to available feeder communication connections.



CrossLinc technology [®] (LN-25X, Activ8X, CrossLinc Remote)

CrossLinc technology communicates through a standard weld cable to enable voltage or current control at the arc without a control cable.



5-pin Control Cable Connection (Lincoln Electric Power Feed wire feeder models)

5-pin high-speed digital communication enables advanced process capability and additional operator controls. Allows compatibility with future wire feeder models.



14-pin (Lincoln Electric LF, LN and Flex Feed[®] models)

14-pin analog communication enables compatibility with most existing Lincoln wire feeders.



Across-the-arc Connection

Across-the-arc feeders connect to the power source using the weld cables. This basic configuration does not use a control cable or CrossLinc Technology, so voltage control is only accessed at the welding power source.



CrossLinc with True Voltage Technology (TVT) – Improve all aspects of your operation with CrossLinc and TVT.



Safety

- Reduce jobsite clutter by removing cumbersome control cables.
- Eliminate unnecessary movement of personnel across the jobsite.
- No need to drag heavy control cables around the jobsite.



Quality

- Full output control at the arc results in the correct settings for every weld.
- True Voltage Technology (TVT) accurately compensates for voltage drop across long cable runs.
- Eliminate unintentional machine adjustments by helpers or other operators.



Productivity

- Setup faster with fewer cable connections.
- Eliminate helpers or trips to the power source to make procedure adjustments.
- Minimize rework with easy settings adjustments.

CrossLinc allows for amperage and voltage control at the welding arc to improve control of your operation.

- No need for an additional control cable – communication occurs directly over the weld cables:
 1. Set the desired voltage on the CrossLinc wire feeder
 2. The feeder sends a signal to the CrossLinc power source.
 3. The power source will change to the desired voltage

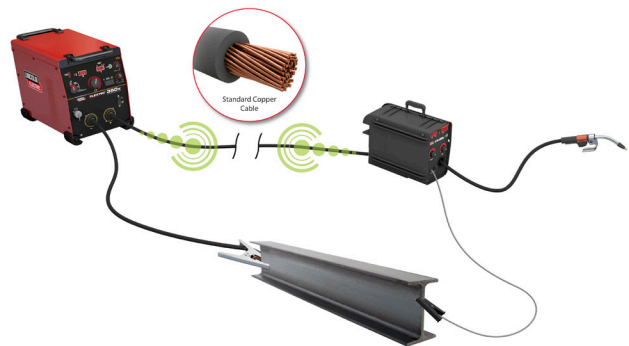

CrossLinc also features True Voltage Technology to compensate for voltage drop across the welding circuit.

- TVT will measure the voltage drop and adjust the power source to compensate for the difference between the desired voltage and actual voltage at the weld.
 1. Preset the wire feeder to the desired voltage.
 2. Make a test weld.
 3. The system will measure voltage drop and automatically adjust the power source to compensate.

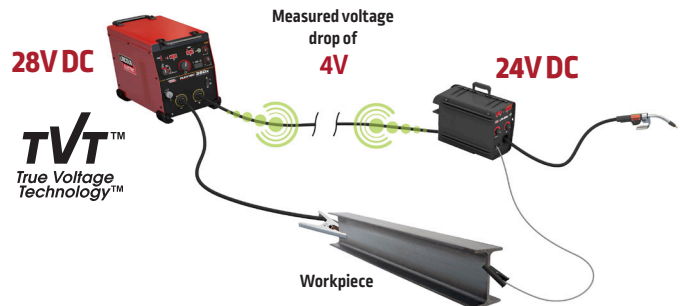

PULSE

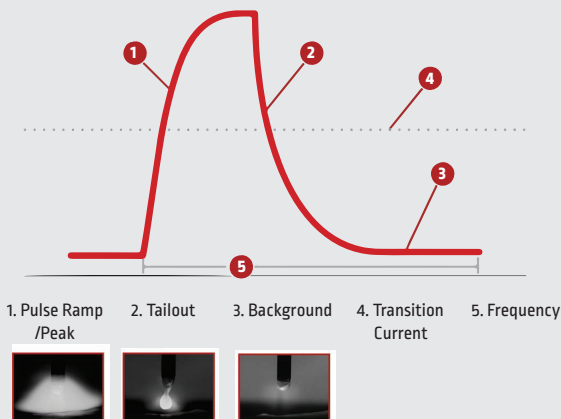

Pulsed spray is a non-contact transfer method between the electrode and the weld puddle. This means that at no time does the electrode ever touch the puddle. This is accomplished through high-speed manipulation of the electrical output of the welding machine. It is designed to be a spatterless process that will run at a lower heat input than spray or globular transfer methods.

Advantages provided by pulsing machines include:

- Spatter and fume reduction
- Heat reduction
- Improved productivity
- Better control

KEY SYSTEM CONFIGURATIONS

Field Setup

On the construction site or in the shipyard, the Flextec 500X welder has you covered. When paired with a CrossLinc technology enabled feeder, you can control the voltage right at the arc, without the need for extra cables.

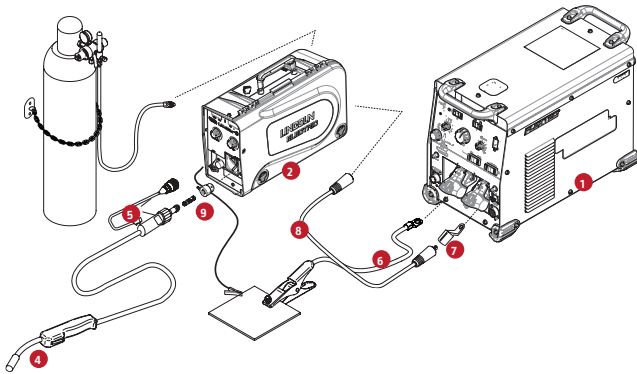

ITEM	DESC.	K#	
1	Machine	Flextec 500X	K3607-1
2	Feeder	LN-25X™	K4267-1
3	Control Cable	None	K4267-1
4	Gun	Magnum® PRO Curve™ 400, 15 ft Ready-Pak® Tweco® #4	K2952-2-10-45
5	Gun Connector Kit	Tweco #2 - #4 Gun back end for Magnum PRO Guns	K466-10 (Included with Gun)
6	Work Cable	Work cable 15 ft. 4/0 cable lug to lug and ground clamp	K2149-1
7	Adapter	Lug to Tweco Adapter	K2487-1
8	Weld power Cable	Tweco style male & female (3/0, 600A, 60%) - 50 ft (15.3 m)	K2485-3
9	Feeder Bushing	10-Series Tweco #2 - #4	K1500-2 (Included with Feeder)

Factory Setup

The multi-process Flextec 500X welder will satisfy all your fabrication needs.

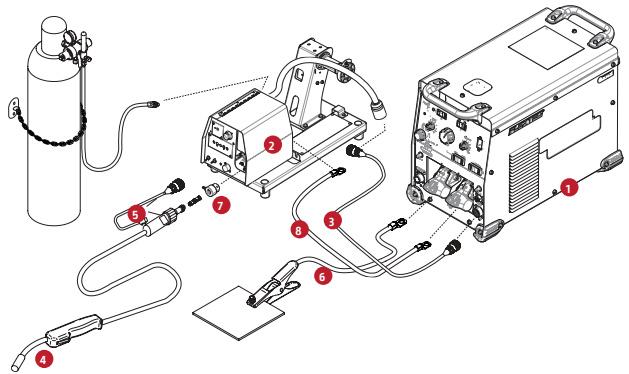

ITEM	DESC.	K#	
1	Machine	Flextec 500X welder	K3607-1
2	Feeder	LF-74	K2426-5
3	Control Cable	14-pin Male to 14-Pin Female Extension	K1797-xx (10 Ft. Cable Included with Feeder)
4	Gun	Magnum PRO Curve 400, 15 ft Ready-Pak Tweco #4	K2952-2-10-45
5	Gun Connector Kit	Tweco #2 - #4 Gun back end for Magnum PRO Guns	K466-10 (Included with Gun)
6	Work Cable	Work cable 15 ft. 4/0 cable lug to lug and ground clamp	K2149-1
7	Feeder Bushing	10-Series Tweco #2 - #4	K1500-2 (Included with Feeder)
8	Weld Power Cable	Lug to Lug 4/0 10ft.	K1842-10

Pulse Setup

To unlock the full potential of the Flextec 500X welder, Connect an ArcLink technology capable feeder. This will give you access to multiple synergic pulse modes. Synergic pulse modes give you all the benefits of pulsed MIG welding without any of the hassle. Just pick your mode and wire speed and the machine will do the rest.

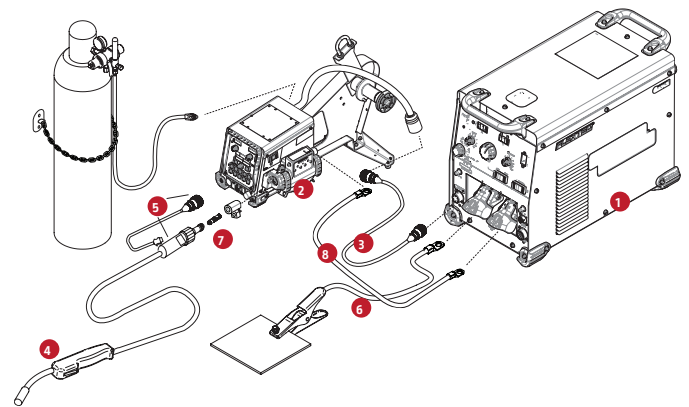

Synergic Pulse Modes

Wire Size	Wire Size			
	Steel	Stainless	Metalcore	Aluminum
0.035	•	•		•
0.040	•			
0.045	•	•	•	
3/64				•
0.052	•		•	
1/16	•	•	•	•

ITEM	DESC.	K#	
1	Machine	Flextec 500X welder	K3607-1
2	Feeder	PF-84 Single Bench HD	K3328-13
3	Control Cable	5-pin ArcLink technology Male to 5-pin ArcLink technology Female. Standard Duty	K1543-xx (10 Ft. Cable Included with Feeder)
4	Gun	Magnum PRO Curve 400, 15 ft Ready-Pak Tweco #4	K2952-2-10-45
5	Gun Connector Kit	Tweco #2 - #4 Gun back end for Magnum PRO Guns	K466-10 (Included with Gun)
6	Work Cable	Work cable 15 ft. 4/0 cable lug to lug and ground clamp	K2149-1
7	Feeder Bushing	10-Series Tweco #2 - #4	K3345-1 (Included with Feeder)
8	Weld Power Cable	Lug to Lug 4/0 10ft.	K1842-10

FLEXTEC 500X Controls »

1. Amperage Display Meter
2. Thermal LED
3. Output Control Dial
4. Hot Start Control Dial
5. Weld Process Selector Switch
6. Local/Remote Output Selector Toggle Switch
7. Circuit Breaker Reset Button for the 5-pin Wire Feeder Connector
8. 5-pin ArcLink Wire Feeder Connector
9. Positive and Negative 1/2 in. (12.7 mm) Welding Output Studs
10. VRD® (Voltage Reduction Device) Indicator Lights
11. CrossLinc indicator light
12. Voltage Display Meter
13. Power Switch
14. Arc Force Control Dial
15. Weld Terminals On/Remote Selector Switch
16. Circuit Breaker Reset Button for the 14-pin Wire Feeder Connector
17. Remote Output Control (12-pin Universal Connector)
18. 14-pin Wire Feeder Connector
19. Wire Feeder Voltmeter Polarity Selection Switch
20. Input Power Cord Strain Relief
21. Input Power Terminal Block
22. Input Fuse
23. Input Power Reconnect
24. Cooling Fan

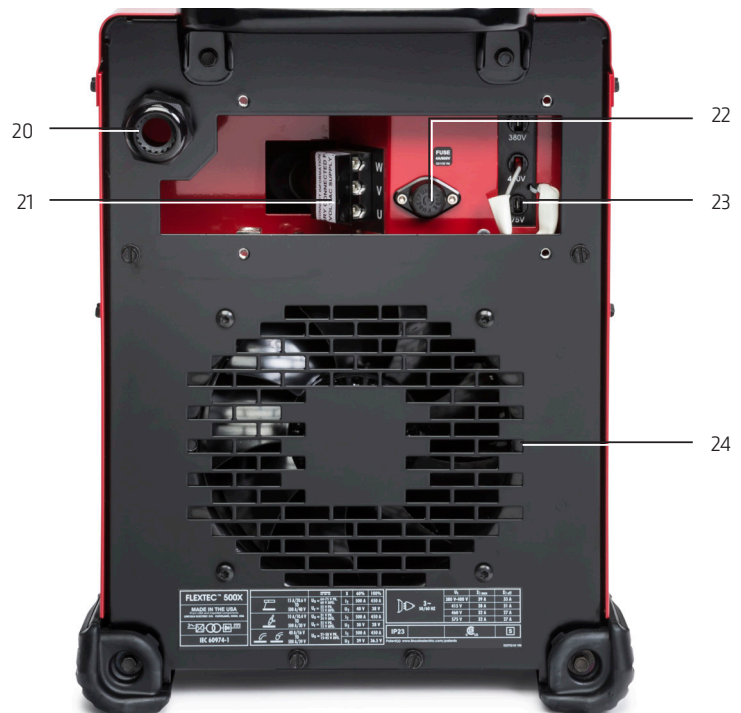

WHAT'S INCLUDED

Description	Product Number	Ready-Pak®				One-Pak®							
		LF-72 Heavy Duty (K3608-1)	LF-74 Heavy Duty (K3608-2)	Power Feed 84 Heavy Duty (K3608-3)	Flex Feed 84 (K3608-4)	LF-72 Heavy Duty (K3612-1)	LF-74 Heavy Duty (K3612-2)	Flex Feed 74HT (K3612-3)	Flex Feed 84 Heavy Duty (K3612-4)	Power Feed 84 Heavy Duty (K3612-5)	LN-25X (K3612-6)	Activ8X (K3612-7)	PF-25M / Magnum PRO AL (K3612-8)
Flextec 500X	K3607-1	•	•	•	•	•	•	•	•	•	•	•	•
Wire Feeders													
Power Feed 84, Heavy Duty Wire Reel Stand, U/I, USB	K3328-13			•						•			
Flex Feed 84 Single Bench Model, Heavy Duty Wire Reel Stand	K5000-2				•				•				
Flex Feed 74HT, Simple U/I, HD, w/ Gouge Kit	K3883-13							•					
LF-72 Bench Model, Heavy Duty Wire Reel Stand	K2327-7	•				•							
LF-74 Bench Model, Heavy Duty Wire Reel Stand	K2426-5		•				•						
LN-25X	K4267-1									•			
Activ8X	K3519-1										•		
PF 25M	K2536-5												•
Drive Rolls													
4 Roll Drive and Wire Guide Kit 0.040-0.045 (1.0-1.1 mm) Solid Wire	KP1505-045S								•				
4 Roll Drive and Wire Guide Combination Kit 0.035-0.045 (0.9-1.1 mm) Solid Wire	KP1505-1		•	•	•		•			•			
2 Roll Drive and Wire Guide Combination Kit 0.035-0.045 (0.9-1.1 mm) Solid Wire	KP1696-1	•				•							
2 Roll Drive and Wire Guide Combination Kit .052 (1.4 mm) Cored Wire	KP1697-052C									•	•		
2 Roll Drive Roll Kit, 3/64, Aluminum	KP1695-3/64A												•
2 Roll Drive Roll Kit, 1/64, Aluminum	KP1697-1/16A												•
Guns													
Magnum PRO Curve 400 Gun and Cable Ready-Pak - 15 ft (4.5 m) See Bulletin E12.05 ¹	K2952-2-10-45	•	•	•	•	•	•	•	•	•	•	•	
Magnum PRO AL 25ft Air	K3355-2												•
Misc.													
Harris® Flowmeter Regulator and Hose	3100211	•	•	•	•	•	•	•	•	•			
Harris Aluminum Flowmeter/Regulator	3100546												•
Control Cable Extension - Male 14 Pin to Female 14 Pin - 10 ft. (3m)	K1797-10	•	•		•	•	•	•	•				
Armlink Control Cable - 8 ft. (2.4m)	K1543-8			•						•			•
3/0 Welding Cable (10 ft lug to lug)	K1842-10	•	•	•	•	•	•	•	•	•			•
Work Lead Package – 15 ft (4.5 m) cable with GC500 ground clamp	K2149-1	•	•	•	•	•	•	•	•	•			•
Inverter Cart Mounting Bracket Kit – Secures feeder to K3059-4/-5 inverter cart. Compatible with FlexFeed and Power Feed wire feeders.	K4068-1			•	•								
Flextec 500 / 500P Locking Foot Kit – secures Flextec 500/500P to the Inverter Cart, rack and accessories	K3056-2	•	•	•	•								
Inverter and Wire Feeder Cart	K3059-4	•	•	•	•								

Note: Ready-Pak all components including undercarriage are assembled and shipped on one pallet. One-Pak all components are shipped together on one pallet. User must assemble components.

RECOMMENDED ACCESSORIES

GENERAL OPTIONS



Multi-Process Switch
Easily change welding process and polarity without changing cables at the machine
Order K3091-1



Flextec 500X CE Filter Kit
[380-575 Vac]
Order K3129-2



Lug to Tweco Adapter
Order K2487-1



3/0 Welding Cable
Tweco Male & Female (3/0, 600A, 60%) - 50ft. (15.3m)
Order K2458-3



Harris® Model 355 Flowmeter Regulator and Hose
Includes 10 ft. (3.0 m) hose
Order: 3100211



Single Cylinder Inverter and Wire Feeder Cart
Requires K4068-1 mounting bracket for LF, Flex Feed and Power Feed Feeders. Requires locking foot kit for Flexsecs
Order K3059-4



Dual Cylinder Inverter and Wire Feeder Cart
Requires K4068-1 mounting bracket for LF, Flex Feed and Power Feed Feeders. Requires locking foot kit for Flexsecs
Order K3059-5



Inverter Cart Mounting Bracket Kit
Use for mounting Flex Feed or Power Feed (to the K3059-4 inverter cart)
Order K4068-1



Flextec 500X Locking Foot Kit
Allows the Flextec to lock to the inverter cart, Multi-Process Switch, Cool-Arc® 55 water cooler.
Order K3056-2



12-pin to 6-pin Adapter
Allows 6-pin remote controls (K870, K963-3, K857, K4217-1) to be used with 12-pin Universal Connection
Order K2909-1

STICK OPTIONS



CrossLinc Remote
Adjust voltage or current at the arc. For CrossLinc-equipped welders.
See publication MC16-137
Order K4345-1



Remote Output Control with 12-pin Universal Connector
Permits remote adjustment of output
Order K857-2 (25 ft.)
Order K857-3 (100 ft.)



TIG OPTIONS

Wireless Foot Pedal with 6-pin Amphenol®
Permits remote adjustment of output(f)
Order K4217-1



Foot Amptrol with 12-pin Amphenol Connector (25 ft.)
Remote current control for TIG welding
Order K870-2



Hand Amptrol Rotary Track Style, 12-pin Amphenol (25 ft.)
Remote current control for TIG welding
Order K963-4



WIRE FEEDER OPTIONS

LN-25X
Includes CrossLinc communication technology
Order K4267-1



Activ8X
Compact, lightweight, portable feeder with CrossLinc Technology
Order K3519-1



LF-72 Bench Model
Two drive roll feeder designed for MIG and cored wire welding in job shop and manufacturing environments
See Publication E8.11



LF-74 Bench Model
Four drive roll feeder designed for MIG and cored wire welding in job shop and manufacturing environments
See Publication E8.11



Flex Feed 74HT
Four drive-roll, high-torque, industrial semiautomatic wire feeder for general/structural fabrication
See Publication E8.203



Flex Feed 84 Single Bench
Four drive roll feeder with heavy duty wire reel stand for general/structural fabrication
See Publication E8.205



Flex Feed 84 Dual Bench
Four drive roll feeder with heavy duty wire reel stand and contactor for general/structural fabrication
See Publication E8.206



Power Feed 84, Heavy Duty Wire Reel Stand, U/I, USB
Four drive roll, digital ArcLink semiautomatic industrial wire feeder built on a modular platform to be used in a variety of applications
See Publication E8.268

(f) Requires the K2909-1 12-pin to 6-pin adapter if used with Flextec 500X

SPECIFICATIONS

MACHINES	Product Number	Input Power	Rated Output Current/Voltage/ Duty Cycle	Input Current @ Rated Output	Output Range	H x W x D in (mm)	Net Weight lb (kg)
FLEXTEC 500X	K3607-1	380/460/575/3/50/60	500A/40V/60% 450A/38V/100%	39/31/31 33/27/27	5-500A	18.8 x 14 x 27.5 (477 x 356 x 699)	136 (62)

For best welding results with Lincoln Electric equipment, always use Lincoln Electric consumables. Visit www.lincolnelectric.com for more details.

Manufactured at a facility with certified ISO Quality and Environmental Management Systems.

CUSTOMER ASSISTANCE POLICY

The business of The Lincoln Electric Company is manufacturing and selling high quality welding equipment, consumables, and cutting equipment. Our challenge is to meet the needs of our customers and to exceed their expectations. On occasion, purchasers may ask Lincoln Electric for information or advice about their use of our products. Our employees respond to inquiries to the best of their ability based on information provided to them by the customers and the knowledge they may have concerning the application. Our employees, however, are not in a position to verify the information provided or to evaluate the engineering requirements for the particular weldment. Accordingly, Lincoln Electric does not warrant or guarantee or assume any liability with respect to such information or advice. Moreover, the provision of such information or advice does not create, expand, or alter any warranty on our products. Any express or implied warranty that might arise from the information or advice, including any implied warranty of merchantability or any warranty of fitness for any customers' particular purpose is specifically disclaimed.

Lincoln Electric is a responsive manufacturer, but the selection and use of specific products sold by Lincoln Electric is solely within the control of, and remains the sole responsibility of the customer. Many variables beyond the control of Lincoln Electric affect the results obtained in applying these types of fabrication methods and service requirements.

Subject to Change – This information is accurate to the best of our knowledge at the time of printing. Please refer to www.lincolnelectric.com for any updated information.



The Lincoln Electric Company
22801 St. Clair Avenue · Cleveland, OH · 44117-1199 · U.S.A.

www.lincolnelectric.com